

B.Tech. 4th Semester F-Scheme (Mech. Engg.)
Examination, May-2018
KINEMATICS OF MACHINE
Paper-ME-204 F

Time allowed : 3 hours] [Maximum marks : 100

Note : Question No. 1 is compulsory. Attempt any five questions in total. At least one question must be attempt from each section.

1. (a) Discuss the kinematic pair and kinematic link.
- (b) Explain the pressure angle, Circular pitch, Diametral pitch and total depth.
- (c) Discuss the different motion of the follower.
- (d) Differentiate between Belt Drive, Rope Drive and Chain drive. 4×5=20

Section-A

2. Explain in detail the Inversions of the Single Slider Crank Mechanism with diagram. 20
3. In a four bar chain ABCD, AD is fixed and is 150 mm long. The crank AB is 40 mm long and rotates at 120 rpm Clockwise, while the link CD = 80 mm oscillates about D. BC and AD are of equal length. Find the angular velocity of the link CD when angle BAD = 60°. 20

24170-P-3-Q-9 (18)

[P.T.O.]

Section-B

4. Draw the Displacement, velocity and acceleration diagram when the follower moves with simple Harmonic Motion. 20
5. (a) Discuss the law of gearing in detail. 10
- (b) What do you mean by arc of Contact ? 10

Section-C

6. The speed ratio of the reverted gear train as shown in the figure is to be 12. The module pitch of gears A and B is 3.125 mm and of gears C and D is 2.5 mm. Calculate the suitable numbers of teeth for the gears. No gear is to have less than 24 teeth. 20

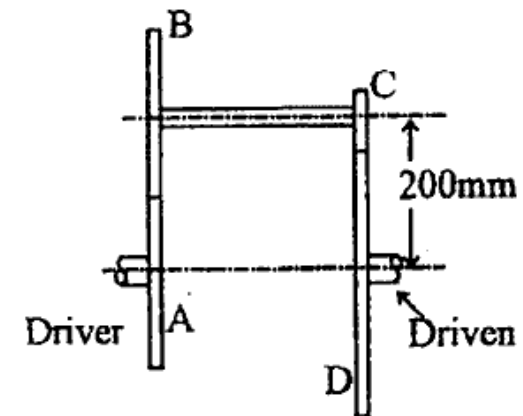

7. Derive the Freudenstein's equation of Four Bar Mechanism for displacement analysis. 20

24170

Section-D

8. An effort of 1500 N is required to just move a certain body up an inclined plane of angle 12° , force acting parallel to the plane. If the angle of inclination is increased to 15° , then the effort required is 1720 N. Find the weight of the body and the Co-efficient of friction. 20
9. Derive the derivation for the ratio of driving tension for Flat Belt Drive. 20

<http://haryanapapers.com>

Whatsapp @ 9300930012

Your old paper & get 10/-

पुराने पेपर्स भेजे और 10 रुपये पायें,

Paytm or Google Pay से